

### Introduction

The GPL1117B series is a series of low dropout three-terminal regulators with a dropout of 1.15V(typ.) at 1A output current.

The GPL1117B series provides current limiting and thermal shutdown. Its circuit includes a trimmed bandgap reference to assure output voltage accuracy to be within 1.5%. Current limit is trimmed to ensure specified output current and controlled short-circuit current. On-chip thermal shutdown provides protection against any combination of overload and ambient temperature that would create excessive junction temperature.

The GPL1117B series has an adjustable version, that can provide the output voltage from 1.25V to 5V with only 2 external resistors.

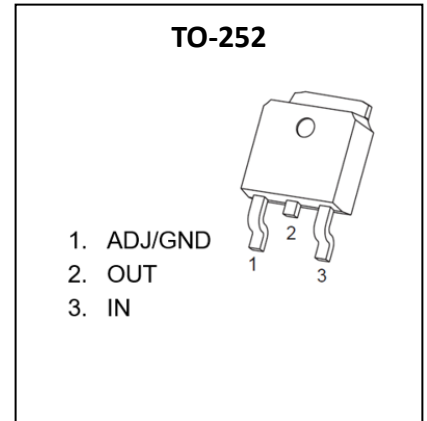

### Features

- Low Dropout Voltage: 1.15V(typ.) at 1A Output Current
- Trimmed Current Limit
- On-Chip Thermal Shutdown
- Three-Terminal Adjustable or Fixed 1.25V, 1.8V, 2.5V, 3.3V, 5V

### Applications

- PC Motherboard
- LCD Monitor
- Graphic Card
- DVD-Video Player
- NIC/Switch
- Telecom Modem
- ADSL Modem
- Printer and Other Peripheral Equipment

### Order Information

GPL1117B①②③④

Designator	Symbol	Description
①②③	Integer	Output Voltage e.g. 1.8V=①:V, ②:1,③:8 ADJ=①②③:ADJ
④	D	Package:TO-252

### Marking

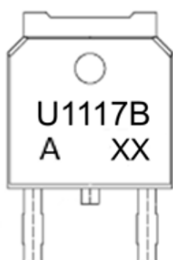

U1117B : Product Code

A: Output Voltage e.g. 3.3V=3.3

XX: Date Code

## Absolute Maximum Ratings<sup>1)</sup> ( $T_A=25^{\circ}\text{C}$ unless otherwise noted)

Parameter	Symbol	Ratings	Units
Input Voltage	$V_{IN}$	20	V
Thermal Resistance from Junction to Ambient	$R_{\theta JA}$	100	$^{\circ}\text{C}/\text{W}$
Operating Junction Temperature Range	$T_j$	-40~125	$^{\circ}\text{C}$
Storage Temperature	$T_{stg}$	-65~150	$^{\circ}\text{C}$
Lead Temperature(Soldering, 10 sec)	$T_{solder}$	260	$^{\circ}\text{C}$
ESD rating	Human Body Model -(HBM)	8	kV
	Machine Model- (MM)	400	V

Note: Stresses greater than those listed under "Absolute Maximum Ratings" may cause permanent damage to the device. These are stress ratings only, and functional of the device at these or any other conditions beyond those indicated under "Recommended Operating Conditions" is not implied. Exposure to "Absolute Maximum Ratings" for extended periods may affect device reliability.

## Electrical Characteristics

GPL117B Series ( $V_{IN} \leq 10V$ ,  $T_A = 25^\circ C$ , unless otherwise specified)

Parameter	Symbol	Conditions	Min.	Typ.	Max.	Units	
Reference Voltage	$V_{IROC}$	$I_{OUT} = 10mA$ , $V_{IN} = 3.23V$	ADJ	1.231	1.25	1.269	V
		$10mA \leq I_{OUT} \leq 1A$ , $2.75V \leq V_{IN} - V_{OUT} \leq 13.25V$	ADJ	1.225	1.25	1.275	V
Output Voltage Range	$V_{OUT}$	$I_{OUT} = 10mA$ , $V_{IN} = 3.8V$	1.8V	1.773	1.8	1.827	V
		$10mA \leq I_{OUT} \leq 1A$ , $3.3V \leq V_{IN} \leq 12V$	1.8V	1.764	1.8	1.836	
		$I_{OUT} = 10mA$ , $V_{IN} = 4.5V$	2.5V	2.463	2.5	2.538	
		$10mA \leq I_{OUT} \leq 1A$ , $4V \leq V_{IN} \leq 12V$	2.5V	2.450	2.5	2.550	
		$I_{OUT} = 10mA$ , $V_{IN} = 5.3V$	3.3V	3.251	3.3	3.350	
		$10mA \leq I_{OUT} \leq 1A$ , $4.8V \leq V_{IN} \leq 12V$	3.3V	3.234	3.3	3.366	
		$I_{OUT} = 10mA$ , $V_{IN} = 7.0V$	5.0V	4.925	5.0	5.075	
		$10mA \leq I_{OUT} \leq 1A$ , $6.5V \leq V_{IN} \leq 12V$	5.0V	4.9	5.0	5.1	
Line Regulation	LNR	$I_{OUT} = 10mA$ , $1.5V \leq V_{IN} - V_{OUT} \leq 12V$	ADJ			0.2	%
		$I_{OUT} = 10mA$ , $1.5V \leq V_{IN} - V_{OUT} \leq 10.2V$	1.8V			7	mV
		$I_{OUT} = 10mA$ , $1.5V \leq V_{IN} - V_{OUT} \leq 9.5V$	2.5V			7	
		$I_{OUT} = 10mA$ , $1.5V \leq V_{IN} - V_{OUT} \leq 8.7V$	3.3V			7	
		$I_{OUT} = 10mA$ , $1.5V \leq V_{IN} - V_{OUT} \leq 7V$	5.0V			10	
Load Regulation	LDR	$V_{IN} - V_{OUT} = 1.5V$ , $10mA \leq I_{OUT} \leq 1A$	ADJ			0.4	%
			1.8V			7.2	mV
			2.5V			10	
			3.3V			13.2	
			5.0V			20	
Adjust Pin Current				60	120	$\mu A$	
Dropout Voltage	$V_{dif}^{(6)}$	$\Delta V_{REF} = 1\%$ , $I_{OUT} = 1.0A$			1.3	V	
Minimum Load Current	$I_L$	$1.5V \leq V_{IN} - V_{OUT} \leq 12V$ (ADJ only)		1.7	5	$\mu A$	
Quiescent Current	$I_q$	$V_{IN} = V_{OUT} + 1.25V$ (ADJ except)			10	mA	
Temperature Stability				0.5		%	
Long-Term Stability		$T_A = 125^\circ C$ , 1000hrs		0.3		%	
RMS Output Noise (% of $V_{OUT}$ )		$T_A = 25^\circ C$ , $10Hz \leq f \leq 10kHz$		0.003		%	
Power Supply Rejection Ratio	PSRR	$f = 120Hz$ , $C_{OUT} = 22\mu F$ Tantalum, $V_{IN} - V_{OUT} = 3V$ , $I_{OUT} = 1A$		75		dB	
Thermal Shutdown Hysteresis	$\Delta T_{SD}$			25		$^\circ C$	

**Functional Block Diagram**

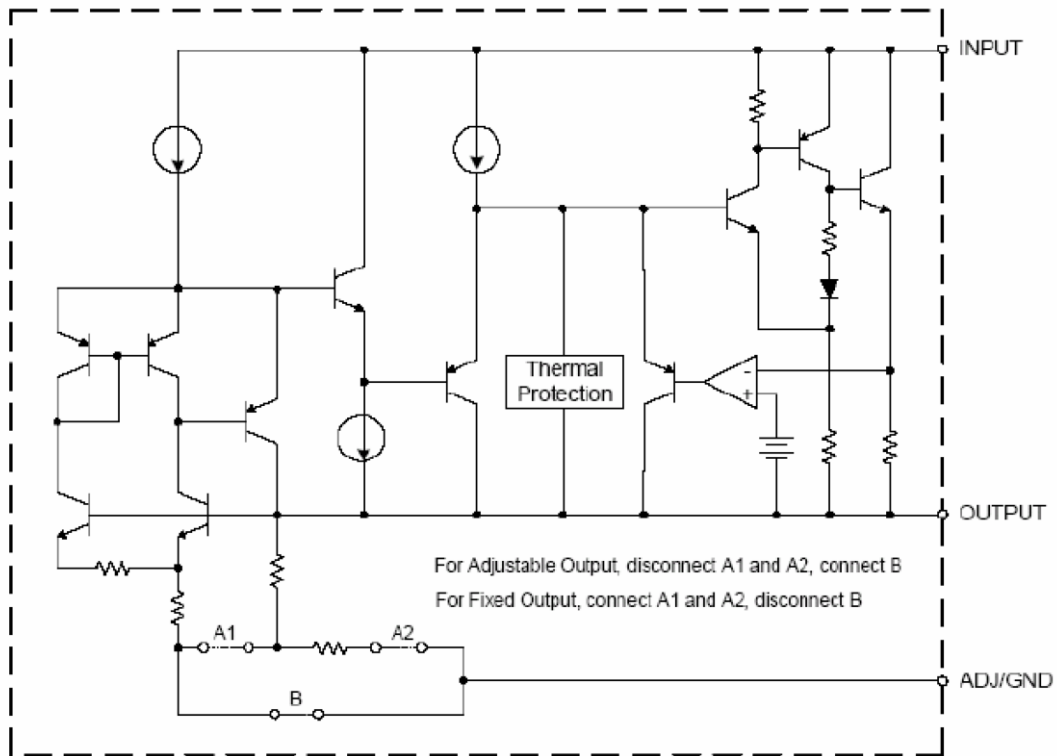

**Typical Application Circuit**

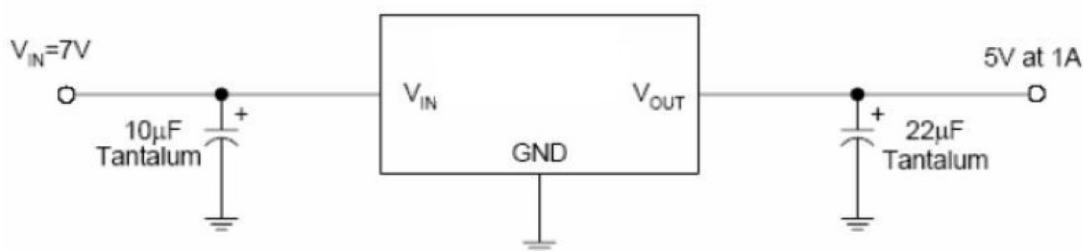
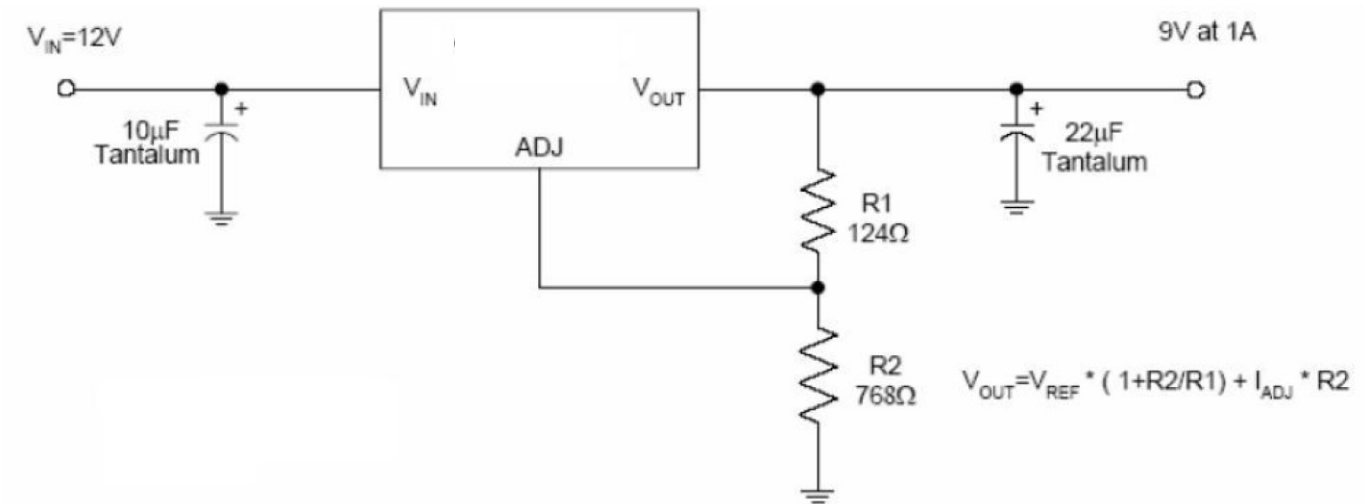

## TO-252 Package Outline Dimensions

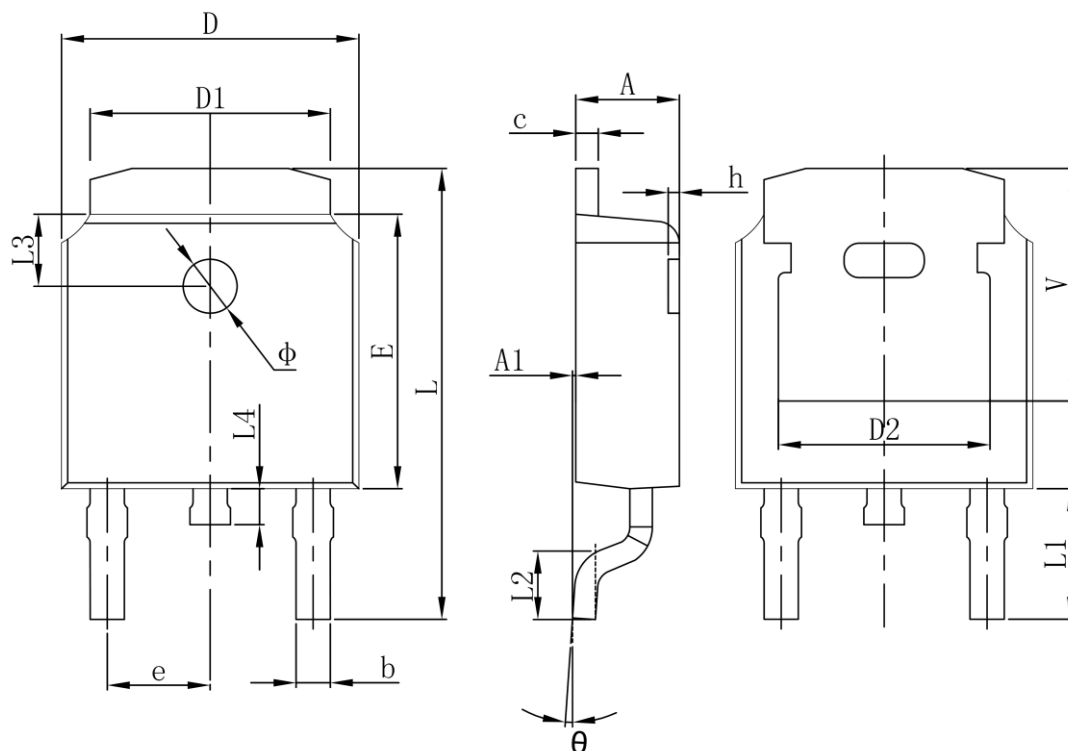

Symbol	Dimensions In Millimeters		Dimensions In Inches	
	Min.	Max.	Min.	Max.
A	2.200	2.400	0.087	0.094
A1	0.000	0.127	0.000	0.005
b	0.635	0.770	0.025	0.030
c	0.460	0.580	0.018	0.023
D	6.500	6.700	0.256	0.264
D1	5.100	5.460	0.201	0.215
D2	4.830REF		0.190REF	
E	6.000	6.200	0.236	0.244
e	2.186	2.386	0.086	0.094
L	9.712	10.312	0.382	0.406
L1	2.900REF		0.114REF	
L2	1.400	1.700	0.055	0.067
L3	1.600REF		0.063REF	
L4	0.600	1.000	0.024	0.039
$\Phi$	1.100	1.300	0.043	0.051
$\theta$	0°	8°	0°	8°
h	0.000	0.300	0.000	0.012
V	5.250REF		0.207REF	